

## *Dura•Drive SPM*



## Installation Services

Sparks Mol has a true nationwide footprint that allows us to call on and service any customer in the continuous 48 states. We make commitments to our clients like few others in the industry. Bottom line is—

**when you need us, we are there.**

## Contact us!

sparksmol.com  
sales@sparksmol.com  
(800) 451-4537 | Fax (800) 338-2358



---

### Headquarters

5005 Kraft Ave. SE, Grand Rapids, MI 49512

### High Performance Fabrication Center

2532 Waldorf Ct. NW, Grand Rapids, MI 49544

# Table of Contents

- DURA-DRIVE SPM Overview**.....4
- Synchronous Permanent Magnet Motor Technology.....4
- Efficiency & Frequency Inverter Operation.....4
- Benefits of the Dura-Drive SPM Pulley.....5
- 3.19 Dura-Drive SPM.....6
  - Dimensions, Performance Specifications, & Motor Data.....7
- 4.39 Dura-Drive SPM.....8
  - Dimensions & Specifications.....9
  - Motor Data.....10
- 5.38 Dura-Drive SPM.....11
  - Dimensions & Specifications.....12
  - Motor Data.....13
- Notes.....14



# Dura•Drive *SPM* is oil-free.

More efficient than AC induction motorized pulleys.

## Synchronous Permanent Magnet Motorized Pulleys

**DURA-DRIVE SPM** pulleys from Sparks Mol have high efficiency synchronous motors as replacements for lower efficiency AC induction motors in conveying applications.

Sparks Mol synchronous motorized pulleys are ideal for applications in logistics, general automation and machine building, and are especially suited for servo-type applications. The motors exceed IE4 efficiency limits, and are designed to meet IE5 requirements.

**DURA-DRIVE SPM** pulleys run oil-free with no possibility of oil leaks. This solves one of the main problems of motorized pulleys, especially in food applications.

## Efficiency Drives Motor Development

The induction motor has been the workhorse of the industry for over 130 years. It is simple to use, robust and fairly inexpensive. However, it is not very efficient. With the increases in energy prices the total cost of ownership of induction motors is increasing rapidly. The cost of running an induction motor over its lifetime is easily 20 times its purchase price, and can be as much as 50 times.

Energy efficiency regulations for electric motors, defined in IEC 60034-30, are an attempt to address this problem by forcing manufacturers to increase efficiency, and by forcing end users to think about energy efficiency and not just purchase price.

The permanent magnet design is the key to high efficiency and high power density of the Sparks Mol **DURA-DRIVE SPM** motorized pulleys.

The optimal volume of NdFeB magnetic material is placed on the rotor maximizing the utilization of the magnetic materials in the motor, and results in the highest possible torque density.

These motors are available in 3.19", 4.39", or 5.38" diameters and can be run either sensor-less in speed control mode or with feedback in combination with a servo drive in position, speed or torque control (sensor-less position control is also possible with some servo drives).

The **DURA-DRIVE SPM** motors are aimed at applications in logistics with high dynamic requirements or as replacements for servo motors in machine building and general automation. They can also be used as a space-saving alternative to a gear motor.

## Frequency Inverter Operation

Frequency inverters (VFD's) are electronic voltage sources that can provide an alternating voltage at variable frequency and amplitude. They are generally used in so called v / f mode (voltage / frequency mode) to control the speed of an induction motor by providing the motor with the required frequency and voltage for a given speed. An induction motor can thus be run in speed control but it is still an induction motor with load dependent speed variation or "slip".

A more complex frequency inverter with a vector-control mode can compensate for this speed variation and can also adjust the motor current according to the load demand. The induction motor still runs asynchronously with slip but the vector controller tries to hold the desired speed, this is the best that can be done with an induction motor.

**A permanent magnet compatible frequency inverter is required to run DURA-DRIVE SPM motorized pulleys.**



## DURA-DRIVE SPM is Sensor-less

In order to control the speed of an induction motor under varying load conditions it is necessary to use a vector controller. This sophisticated mode of control is implemented in a frequency inverter and requires an accurate measurement of the motor current and numerous mathematical vector calculations which are performed to dynamically calculate the required current vector in order to achieve the required torque at any time. These features used to be only available in high-end servo drives using motor feedback. Advances in microprocessor technology and current measurement mean that even low cost frequency inverters have this type of functionality. These developments are the basis of the sensor-less mode of motor control used in the **DURA-DRIVE SPM** motor range.

The frequency inverter uses measurements of phase current and voltage to calculate the instantaneous position of the rotor and to set the current vector correctly to maximize torque. This can all be done without any feedback device making the motor and the whole system, much cheaper. There are now a wide range of frequency inverters in the market that have this capability. In this mode the motor can deliver about 150% of rated torque at start up and can be controlled over a speed range of about 10:1 to 15:1.

## DURA-DRIVE SPM Servo

**DURA-DRIVE SPM** motors can be fitted with a standard feedback device (resolver or Hyperface Sin / Cos encoder) and in combination with most standard servo drives used as a PM servo. Run in this mode, the motor can achieve up to 500% of rated torque and be controlled in a speed range of about 1000:1.

All usual servo applications can be realized: position control, speed control, master-slave, cam follower etc. These are all common operating modes in applications such as packaging, labeling, pick and place, cutting etc.

## Benefits of the DURA-DRIVE SPM Motorized Pulley

- **Oil-free:** provides high power with no need for oil cooling, eliminating any chance of oil leakage
- **Practically no conveyor downtime or maintenance:** means lower costs and higher productivity
- **Compact, safe and clean:** hazards and pinch points are removed by having all moving parts enclosed in the pulley shell, and there is no external grease or oil from chains, bearings and couplings
- **Simple design:** **DURA-DRIVE SPM** is a one-piece pulley so it can be easily specified into new conveyor systems, which dramatically reduces design time. For existing systems the pulleys can be ordered with two mounting brackets for an easy retrofit
- **Synchronous motor technology:** the permanent magnet motors used in **DURA-DRIVE SPM** pulleys are characterized by high power density and very low losses. The motors can be supplied with feedback for use with servo drives, or run sensor-less with a suitable frequency inverter
- **Cool running:** very low losses mean significantly reduced heat when compared to a motorized pulley powered by a standard AC induction motor
- **Torque:** remains constant over a very wide speed range
- **Standardization:** due to the constant torque, one **DURA-DRIVE SPM** can cover a much wider range of applications
- **High acceleration:** for infeed applications, for example a collating conveyor, the **DURA-DRIVE SPM** can provide high acceleration even with large loads
- **Energy efficiency:** the permanent magnet motor is up to 6 times more efficient than an AC induction motor, which reduces operating costs

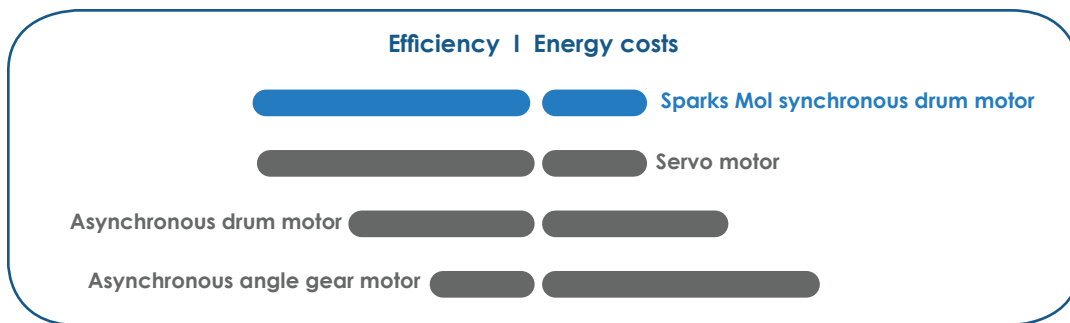

\*Current US Requirement is IE3 or better

# 3.19 Dura•Drive SPM

The **DURA-DRIVE** Synchronous motorized pulleys are high powered, high efficiency motors that help lower energy costs by running more efficiently and in turn, meeting current energy efficiency regulations. The permanent magnet design is the key to the high efficiency and the power density. Best for applications in logistics, general automation, machine building, and are especially suited for servo-type applications.



## Oil-Free

**DURA-DRIVE SPM** pulleys run oil-free meaning no possibility of oil leaks. This solves one of the main problems of motorized pulleys, especially in food applications. Oil-free provides high power with no need for oil cooling eliminating any chance of leakage. Additionally, there is practically no conveyor downtime or maintenance and that leads to lower costs and higher productivity.

## Simple Design

**DURA-DRIVE SPM** is a one-piece pulley so it can be easily specified into new conveyor systems, which dramatically reduces design time. For existing systems the pulleys can be ordered with two mounting brackets for an easy retrofit. Because it's compact, and all moving parts are enclosed in the pulley shell, there is less concern of hazards and pinch points and there's no external grease or oil from chains, bearings and couplings.

## Cool Running

The permanent magnet motor allows for the pulley to run at high power and very low electrical and mechanical losses. This results in significantly reduced heat when compared to a motorized pulley powered by a standard AC induction motor.

## Standardization

Due to the constant torque over a broad speed range, one **DURA-DRIVE SPM** can cover a wide range of applications.

## Constructions & Materials

Component	Standard	Options
Shaft	Mild Steel	Stainless Steel
Shell	Mild Steel	Stainless Steel
	Crowned	Rubber Lagged
		Flat Face
		V-Grooves
		Sprockets
		Hard Chrome
End Caps	Mild Steel	Stainless Steel
Sealing	IP66	IP69K
Electrical Connections	Straight brass connector with 1.5 meter cable (longer cable lengths available)	Stainless Steel elbow connector with 1.5 meter cable (longer cable lengths available)
		Stainless Steel terminal box
Motor Insulation	Class F	

## Electrical Connections

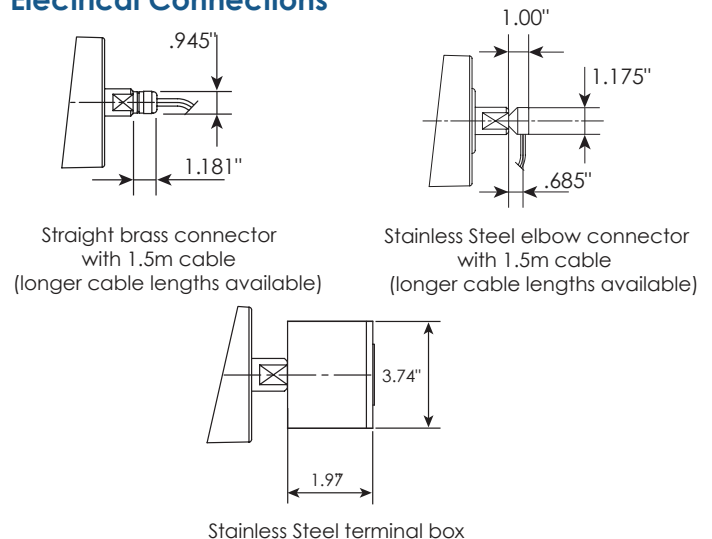



**Motorized and Idler Pulley Dimensions**

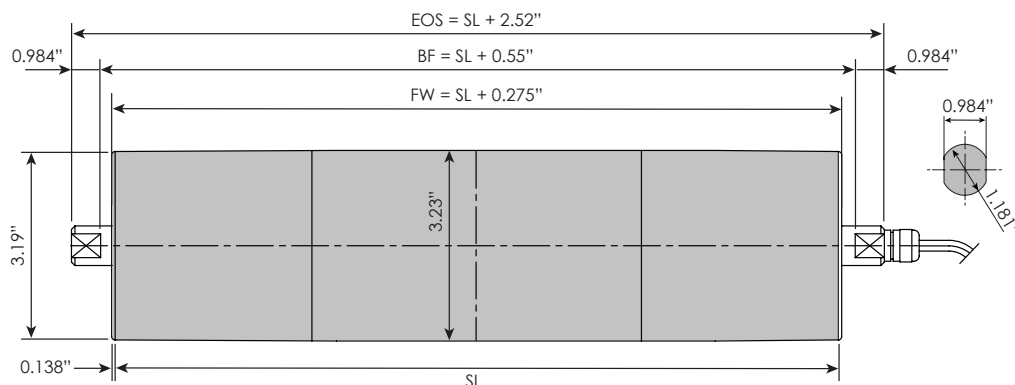

**Mounting Bracket**

Material: Cast iron or stainless steel bracket

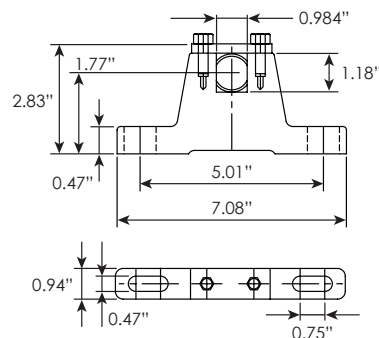

**Standard Gearbox**

HP	Minimum Shell Length	RPM	FPM (nominal)	Belt Pull (lbs)	Drum Torque (lbs ft)
0.50	11.81"	94	79	199	26.6
		150	126	124	16.6
		<b>188</b>	<b>158</b>	<b>99</b>	<b>13.3</b>
		250	211	74	10.0
		375	316	51	6.8

\*\*Bold blue numbers designates special order items.

- Speed adjustments in the following ranges are possible:
  - Sensor-less operation with a suitable frequency inverter: 10:1 is normal, 15:1 possible
  - Servo drive and feedback: up to 1,000:1
- Starting torque:
  - Sensor-less: rated torque x 1.5
  - With feedback: peak torque
- Shell lengths (SL) up to 40", contact Sparks Mol Customer Service for longer lengths
- Other shaft size options are available
- Contact Sparks Mol customer service for lagging and v-groove options

**Motor Data (Required for VFD Programming)**

Motor		0.50HP
Power	HP (kW)	0.50 (0.37)
Nameplate / Maximum Frequency	Hz	150
Nominal rotational speed	$n_n$	3,000
Pole pairs		3
Electrical connection		Y
Stator Rated Voltage	V	181
Rated torque [Nm]	$M_n$	1.2
Nominal current per phase [Arms]	$I_n$	1.5
Stall torque [Nm]	$M_0$	1.5
Locked rotor current per phase [Arms]	$I_0$	1.8
Peak torque [Nm]	$M_{max}$	6.0
Peak current [Arms]	$I_{max}$	7.2
Voltage constant (per 1,000 RPM) [Vrms]	$k_e$	51.7
Back EMF	$V_{rms}$	155.1
Torque constant [Nm/Arms]	$k_t$	0.86
Winding resistance (phase to phase at 68°F) [ $\Omega$ ]	$R_{pp}$	9.8
Winding inductance (phase to phase) [mH]	$L_{pp}$	18.6
Electrical time constant [ms]	$T_{el}$	1.9
Rotor inertia [kgcm <sup>2</sup> ]	J	0.413

## 4.39 Dura•Drive SPM

The **DURA-DRIVE** Synchronous motorized pulleys are high powered, high efficiency motors that help lower energy costs by running more efficiently and in turn, meeting current energy efficiency regulations. The permanent magnet design is the key to the high efficiency and the power density. Best for applications in logistics, general automation, machine building, and are especially suited for servo-type applications.



### Oil-Free

**DURA-DRIVE SPM** pulleys run oil-free meaning no possibility of oil leaks. This solves one of the main problems of motorized pulleys, especially in food applications. Oil-free provides high power with no need for oil cooling eliminating any chance of leakage. Additionally, there is practically no conveyor downtime or maintenance and that leads to lower costs and higher productivity.

### Simple Design

**DURA-DRIVE SPM** is a one-piece pulley so it can be easily specified into new conveyor systems, which dramatically reduces design time. For existing systems the pulleys can be ordered with two mounting brackets for an easy retrofit. Because it's compact, and all moving parts are enclosed in the pulley shell, there is less concern of hazards and pinch points and there's no external grease or oil from chains, bearings and couplings.

### Cool Running

The permanent magnet motor allows for the pulley to run at high power and very low electrical and mechanical losses. This results in significantly reduced heat when compared to a motorized pulley powered by a standard AC induction motor.

### Standardization

Due to the constant torque over a broad speed range, one **DURA-DRIVE SPM** can cover a wide range of applications.

### Constructions & Materials

Component	Standard	Options
Shaft	Mild Steel	Stainless Steel
Shell	Mild Steel	Stainless Steel
	Crowned	Rubber Lagged
		Flat Face
		V-Grooves
		Sprockets
		Hard Chrome
End Caps	Mild Steel	Stainless Steel
Sealing	IP66	IP69K
Electrical Connections	Straight brass connector with 1.5 meter cable (longer cable lengths available)	Stainless Steel elbow connector with 1.5 meter cable (longer cable lengths available)
		Stainless Steel terminal box
Motor Insulation	Class F	

### Electrical Connections

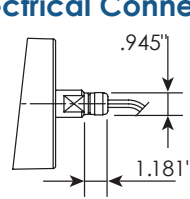

Straight brass connector with 1.5m cable (longer cable lengths available)

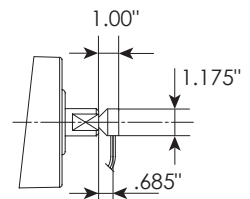

Stainless Steel elbow connector with 1.5m cable (longer cable lengths available)

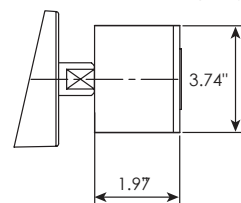

Stainless Steel terminal box



**Motorized and Idler Pulley Dimensions**

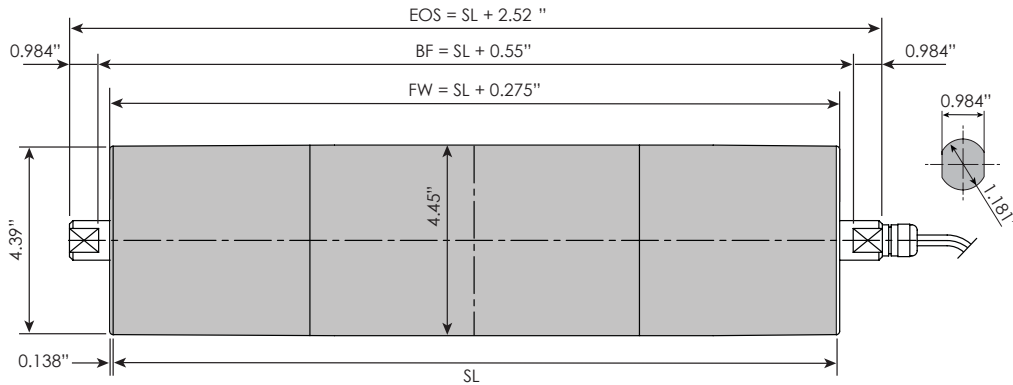

**Mounting Bracket**

Material: Cast iron or stainless steel bracket

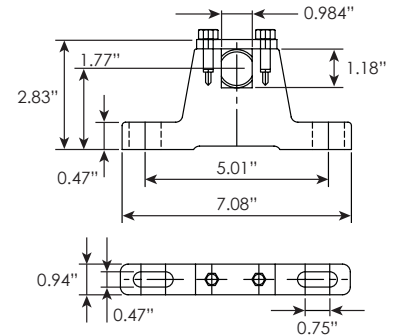

**Standard Gearbox**

HP	Minimum Shell Length	RPM	FPM (nominal)	Belt Pull (lbs)	Drum Torque (lbs ft)
0.50	11.81"	94	109	144	26.6
		150	175	90	16.6
		<b>188</b>	<b>218</b>	<b>72</b>	<b>13.3</b>
		250	291	54	10.0
		375	437	37	6.8
1.0	12.17"	94	109	175	32.5
		<b>150</b>	<b>175</b>	<b>172</b>	<b>31.9</b>
		<b>188</b>	<b>218</b>	<b>138</b>	<b>25.5</b>
		<b>250</b>	<b>291</b>	<b>103</b>	<b>19.1</b>
		<b>375</b>	<b>437</b>	<b>70</b>	<b>13.0</b>
1.35	12.96"	<b>94</b>	<b>109</b>	<b>175</b>	<b>32.5</b>
		<b>150</b>	<b>175</b>	<b>175</b>	<b>32.5</b>
		188	218	175	32.5
		<b>250</b>	<b>291</b>	<b>144</b>	<b>26.6</b>
		375	437	72	13.3

\*\*Bold blue numbers designates special order items.

**Heavy Duty Gearbox**

HP	Minimum Shell Length	RPM	FPM (nominal)	Belt Pull (lbs)	Drum Torque (lbs ft)
1.0	15.35"	<b>74</b>	<b>87</b>	<b>344</b>	<b>64</b>
		<b>94</b>	<b>109</b>	<b>275</b>	<b>51</b>
		<b>150</b>	<b>175</b>	<b>172</b>	<b>32</b>
		<b>188</b>	<b>218</b>	<b>138</b>	<b>26</b>
		298	349	88	16
1.35	15.35"	74	87	442	81
		<b>94</b>	<b>109</b>	<b>386</b>	<b>71</b>
		120	141	293	54
		<b>150</b>	<b>175</b>	<b>241</b>	<b>44</b>
		<b>188</b>	<b>218</b>	<b>193</b>	<b>35</b>
	14.96"	298	349	123	23

\*\*Bold blue numbers designates special order items.

- Speed adjustments in the following ranges are possible:
  - Sensor-less operation with a suitable frequency inverter: 10:1 is normal, 15:1 possible
  - Servo drive and feedback: up to 1,000:1
- Starting torque:
  - Sensor-less: rated torque x 1.5
  - With feedback: peak torque
- Standard shell lengths (SL) up to 40 contact Sparks Mol customer service for longer shell lengths
- Other shaft size options are available
- Contact Sparks Mol customer service for lagging and v-groove options



### Motor Data (Required for VFD Programming)

Motor		0.50HP	1.0HP (230V Input)	1.0HP (460V Input)	1.35HP (230V Input)	1.35HP (460V Input)
Power	HP (kW)	0.50 (0.38)	1.0 (0.72)	1.0 (0.72)	1.35 (1.01)	1.35 (1.01)
Nameplate / Maximum Frequency	Hz	150	150	150	150	150
Nominal rotational speed	$n_n$	3,000	3,000	3,000	3,000	3,000
Pole pairs		3	3	3	3	3
Electrical connection		Y	Y	Y	Y	Y
Stator Rated Voltage	V	181	181	320	181	320
Rated torque [Nm]	$M_n$	1.2	2.3	2.3	3.2	3.2
Nominal current per phase [Arms]	$I_n$	1.5	2.6	1.6	3.7	2.1
Stall torque [Nm]	$M_0$	1.5	2.8	2.8	3.5	3.5
Locked rotor current per phase [Arms]	$I_0$	1.8	3.1	1.8	3.9	2.2
Peak torque [Nm]	$M_{max}$	6.0	11.2	11.2	14.0	14.0
Peak current [Arms]	$I_{max}$	7.2	12.4	7.2	15.6	8.8
Voltage constant (per 1,000 RPM) [Vrms]	$k_e$	51.7	54.3	95.3	55.0	97.5
Back EMF	$V_{rms}$	155.1	162.9	285.9	165.0	292.5
Torque constant [Nm/Arms]	$k_t$	0.86	1.58	1.58	1.61	1.61
Winding resistance (phase to phase at 68°F) [ $\Omega$ ]	$R_{pp}$	9.8	4.6	14.2	2.8	9.0
Winding inductance (phase to phase) [mH]	$L_{pp}$	18.6	11.8	36.2	8.4	26.0
Electrical time constant [ms]	$T_{el}$	1.9	2.6	2.5	3.0	2.9
Rotor inertia [kgcm <sup>2</sup> ]	J	0.413	1.40	1.40	1.40	1.93

## 5.38 Dura•Drive SPM

The **DURA-DRIVE** Synchronous motorized pulleys are high powered, high efficiency motors that help lower energy costs by running more efficiently and in turn, meeting current energy efficiency regulations. The permanent magnet design is the key to the high efficiency and the power density. Best for applications in logistics, general automation, machine building, and are especially suited for servo-type applications.



### Oil-Free

**DURA-DRIVE SPM** pulleys run oil-free meaning no possibility of oil leaks. This solves one of the main problems of motorized pulleys, especially in food applications. Oil-free provides high power with no need for oil cooling eliminating any chance of leakage. Additionally, there is practically no conveyor downtime or maintenance and that leads to lower costs and higher productivity.

### Simple Design

**DURA-DRIVE SPM** is a one-piece pulley so it can be easily specified into new conveyor systems, which dramatically reduces design time. For existing systems the pulleys can be ordered with two mounting brackets for an easy retrofit. Because it's compact, and all moving parts are enclosed in the pulley shell, there is less concern of hazards and pinch points and there's no external grease or oil from chains, bearings and couplings.

### Cool Running

The permanent magnet motor allows for the pulley to run at high power and very low electrical and mechanical losses. This results in significantly reduced heat when compared to a motorized pulley powered by a standard AC induction motor.

### Standardization

Due to the constant torque over a broad speed range, one **DURA-DRIVE SPM** can cover a wide range of applications.

### Constructions & Materials

Component	Standard	Options
Shaft	Mild Steel	Stainless Steel
Shell	Mild Steel	Stainless Steel
	Crowned	Rubber Lagged
		Flat Face
		V-Grooves
		Sprockets
		Hard Chrome
End Caps	Mild Steel	Stainless Steel
Sealing	IP66	IP69K
Electrical Connections	Straight brass connector with 1.5 meter cable (longer cable lengths available)	Stainless Steel elbow connector with 1.5 meter cable (longer cable lengths available)
		Stainless Steel terminal box
Motor Insulation	Class F	

### Electrical Connections

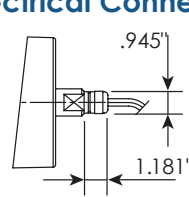

Straight brass connector with 1.5m cable (longer cable lengths available)

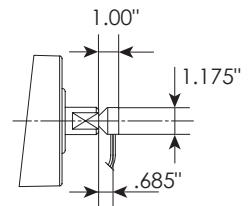

Stainless Steel elbow connector with 1.5m cable (longer cable lengths available)

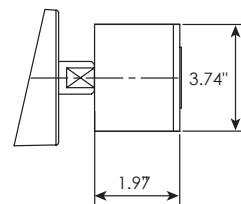

Stainless Steel terminal box



**Motorized and Idler Pulley Dimensions**

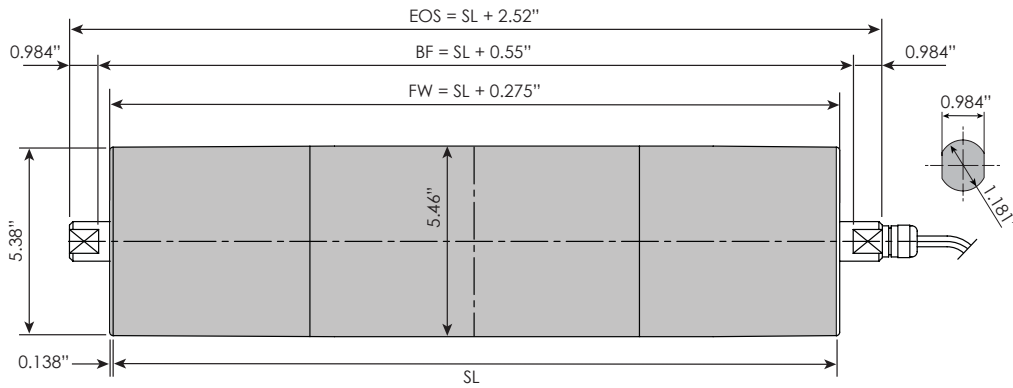

**Mounting Bracket**

Material: Cast iron or stainless steel bracket

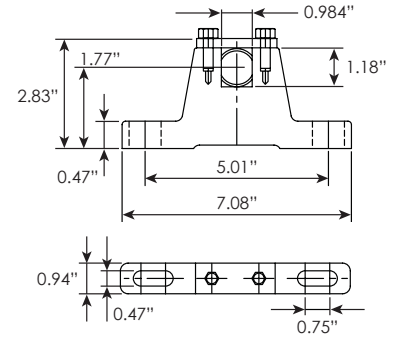

**Standard Gearbox**

HP	Minimum Shell Length	RPM	FPM (nominal)	Belt Pull (lbs)	Drum Torque (lbs ft)
1.0	15.35"	<b>74</b>	<b>107</b>	<b>282</b>	<b>64</b>
		<b>94</b>	<b>134</b>	<b>225</b>	<b>51</b>
<b>150</b>		<b>214</b>	<b>141</b>	<b>36</b>	
<b>188</b>		<b>267</b>	<b>113</b>	<b>26</b>	
	14.96"	<b>298</b>	<b>428</b>	<b>72</b>	<b>16</b>
1.35	15.35"	74	107	358	81
		<b>94</b>	<b>134</b>	<b>314</b>	<b>71</b>
		120	171	238	54
		<b>150</b>	<b>214</b>	<b>196</b>	<b>44</b>
		<b>188</b>	<b>267</b>	<b>157</b>	<b>36</b>
	14.96"	298	428	100	23
2	16.14"	<b>74</b>	<b>107</b>	<b>586</b>	<b>133</b>
	15.53"	<b>150</b>	<b>214</b>	<b>299</b>	<b>168</b>
	14.96"	<b>298</b>	<b>428</b>	<b>124</b>	<b>28</b>

\*\*Bold blue numbers designates special order items.

- Speed adjustments in the following ranges are possible:
  - Sensor-less operation with a suitable frequency inverter: 10:1 is normal, 15:1 possible
  - Servo drive and feedback: up to 1,000:1
- Starting torque:
  - Sensor-less: rated torque x 1.5
  - With feedback: peak torque
- Standard shell lengths (SL) up to 40", contact Sparks Mol customer service for longer shell lengths
- Other shaft size options are available
- Contact Sparks Mol customer service for lagging and v-groove options

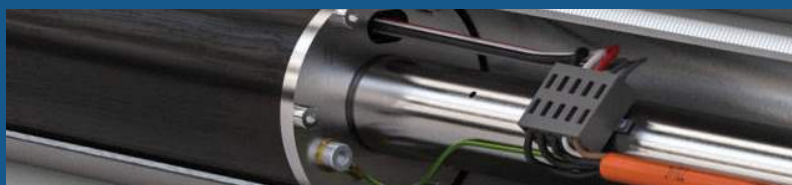

### Motor Data (Required for VFD Programming)

Motor		1.0HP (230V Input)	1.0HP (460V Input)	1.35HP (230V Input)	1.35HP (460V Input)	2.00HP (230V Input)	2.00HP (460V Input)
Power	HP (kW)	1.0 (0.72)	1.0 (0.72)	1.35 (1.01)	1.35 (1.01)	2.0 (1.5)	2.0 (1.5)
Nameplate / Maximum Frequency	Hz	150	150	150	150	150	150
Nominal rotational speed	$n_n$	3,000	3,000	3,000	3,000	3,000	3,000
Pole pairs		3	3	3	3	3	3
Electrical connection		Y	Y	Y	Y	Y	Y
Stator Rated Voltage	V	181	320	181	320	171	318
Rated torque [Nm]	$M_n$	2.3	2.3	3.2	3.2	3.53	3.53
Nominal current per phase [Arms]	$I_n$	2.6	1.6	3.7	2.1	6.1	3.3
Stall torque [Nm]	$M_0$	2.8	2.8	3.5	3.5	3.69	3.69
Locked rotor current per phase [Arms]	$I_0$	3.1	1.8	3.9	2.2	6.1	3.3
Peak torque [Nm]	$M_{max}$	11.2	11.2	14.0	14.0	8.81	8.81
Peak current [Arms]	$I_{max}$	12.4	7.2	15.6	8.8	15.3	8.3
Voltage constant (per 1,000 RPM) [Vrms]	$k_e$	54.3	95.3	55.0	97.5	51.2	100.5
Back EMF	$V_{rms}$	162.9	285.9	165.0	292.5	153.6	301.5
Torque constant [Nm/Arms]	$k_t$	1.58	1.58	1.61	1.61	.58	1.07
Winding resistance (phase to phase at 68°F) [ $\Omega$ ]	$R_{pp}$	4.6	14.2	2.8	9.0	1.9	7.1
Winding inductance (phase to phase) [mH]	$L_{pp}$	11.8	36.2	8.4	26.0	12.5	43
Electrical time constant [ms]	$T_{el}$	2.6	2.5	3.0	2.9	6.6	6.1
Rotor inertia [kgcm <sup>2</sup> ]	J	1.40	1.40	1.40	1.93	0.591	0.591

# Dura-Drive SPM

## Dura-Drive SPM Servo

**DURA-DRIVE SPM** motors can be fitted with a standard feedback device (resolver or Hyperface Sin / Cos encoder) and in combination with most standard servo drives used as a PM servo. Run in this mode, the motor can achieve up to 500% of rated torque and be controlled in a speed range of about 1000:1.

Servo Drives	
Manufacturer	Type
Lenze	Servodrive 9400 HighLine (Resolver)
Schneider Electric	PAC Drive 3 (SKS36)
KEB	Combivert F5 (Resolver)
	Combivert S6 (Resolver & Sensorless)

Frequency Inverter/Sensorless	
Manufacturer	Type
Allen Bradley	<b>PowerFlex 525</b>
	PowerFlex 753
Invertek	Optidrive P2
	Optidrive E3
Lenze	i550
	Highline 8400
	Stateline 8400
Hitachi	WJ200
Nord	SK 215E
SEW	Movitrac LTP-B
Schneider Electric	Altivar 32

\*\*The inverters in bold blue print above are stocked by Sparks Mol and come pre-programmed.

## Connector Pin Assignment

### Power

Color/Code	Function
black/1	U
black/2	V
black/3	W
green-yellow	ground
brown	thermal
white	thermal

### Resolver

Color/Code	Function
white	REF +
brown	REF -
green	SIN +
yellow	SIN -
pink	COS +
grey	COS -

### SKS36 Encoder

Color/Code	Function
grey	DATA +
green	DATA -
white	SIN +
brown	REF SIN
pink	COS +
black	REF COS
red	US (8 V DC)
blue	GND (0 V DC)

## Thermal Protection

The **DURA-DRIVE SPM** motorized pulley is fitted with either a KTY84-130 switch or PTC temperature sensor. The temperature sensor must be monitored by an external circuit, such as a frequency inverter, which switches off the power to the motor if the maximum temperature is exceeded.

### Option: Motor feedback

**DURA-DRIVE SPM** motorized pulleys can be supplied with resolver or SKS36 feedback.

## Resolver

<b>Number of poles</b>	2
<b>Input frequency</b>	10kHz
<b>Input voltage</b>	Vrms
<b>Connection</b>	Signal cable 6 x 0.14 qmm (AWG 26) shielded

\*The optional components increase the minimum face width of the pulley by +1.34".

## SKS36 Encoder

<b>Number of Sin/Cos periods per revolution</b>	128
<b>Number of absolute revolutions</b>	1 (single turn)
<b>Resolution</b>	4096
<b>Connection</b>	Signal cable 8 x 0.15 qmm (AWG 26) shielded
<b>Supply voltage</b>	7 to 12V DC

\*The optional components increase the minimum face width of the pulley by +2.09".



