

Dura•Drive Plus

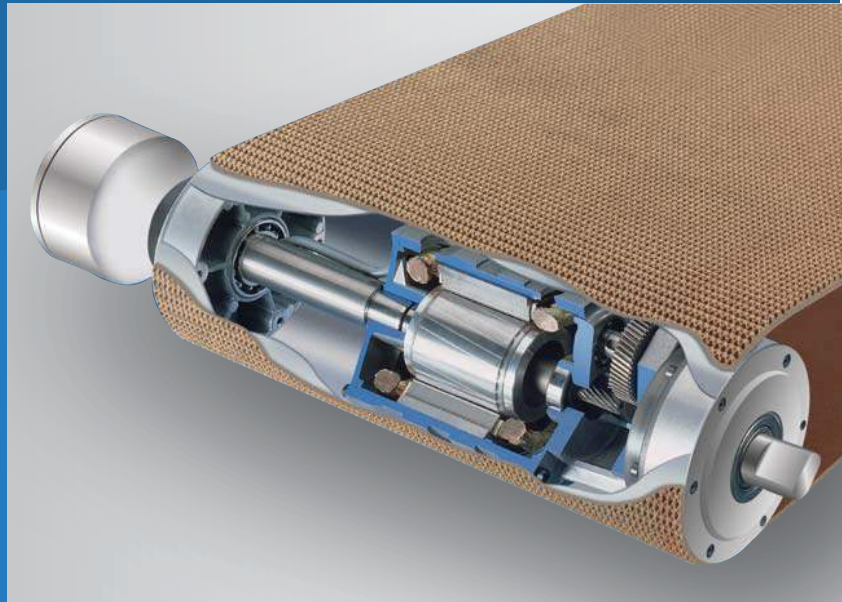

Installation Services

Sparks Mol has a true nationwide footprint that allows us to call on and service any customer in the continuous 48 states. We make commitments to our clients like few others in the industry. Bottom line is—

when you need us, we are there.

Contact us!

sparksmol.com
sales@sparksmol.com
(800) 451-4537 | Fax (800) 338-2358



Headquarters

5005 Kraft Ave. SE, Grand Rapids, MI 49512

High Performance Fabrication Center

2532 Waldorf Ct. NW, Grand Rapids, MI 49544

Table of Contents

- DURA-DRIVE Plus** Overview.....4
- What is a Motorized Pulley?.....5
- Features & Benefits.....5
- 3.19 Dura-Drive *Plus*.....6
 - Dimensions & Specifications.....7
- 4.39 Dura-Drive *Plus*.....8
 - Dimensions & Specifications.....9
- 5.38 Dura-Drive *Plus*.....10
 - Dimensions & Specifications.....11
- 6.46 Dura-Drive *Plus*.....12
 - Dimensions & Specifications.....13
- 8.48 Dura-Drive *Plus*.....14
 - Dimensions & Specifications.....15



Dura•Drive *Plus* vs.

Conventional chain or v-belt drive systems:
by every important measure, it's no comparison.

Unlike conventional drive systems, the new **DURA-DRIVE PLUS** motorized pulley has no chains or V-belts to tighten or replace, no sprockets to align, clean or lubricate, no bearings to grease, and doesn't require chain guards that need replacing.

It's a simple - yet small and powerful - one-piece motorized pulley that's guaranteed to power your belt conveyor for years without breakdown. All gearing is made of high-quality alloy steel, not plastic. Just an in-place oil change after 25,000 hours is all that's ever needed. No disassembly required.

The result: Almost no maintenance or downtime. And that means lower costs and higher productivity.

Compact, safer, and cleaner operation.

Unlike bulky conventional drive systems that fit externally on a conveyor, **DURA-DRIVE PLUS** is actually part of the conveyor and much more compact. That means you can fit more conveyor into less floor or overhead space.

Also, all moving parts are enclosed in the steel pulley shell, eliminating hazardous moving parts and pinch points, along with the potential for electric shock from water on motors. **DURA-DRIVE PLUS** is cleaner because there's no external grease or oil from chains, bearings or couplings. As a result, you improve worker safety and more readily comply with OSHA standards.

Ample space in terminal box for easy installation

Electric motor wound to minimum Class F

No-maintenance bearing is continually lubricated

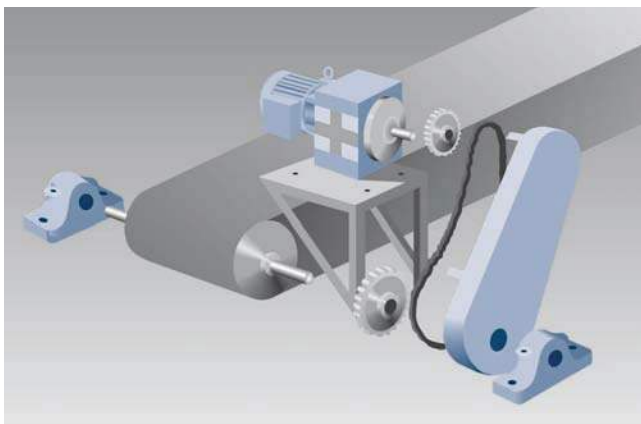
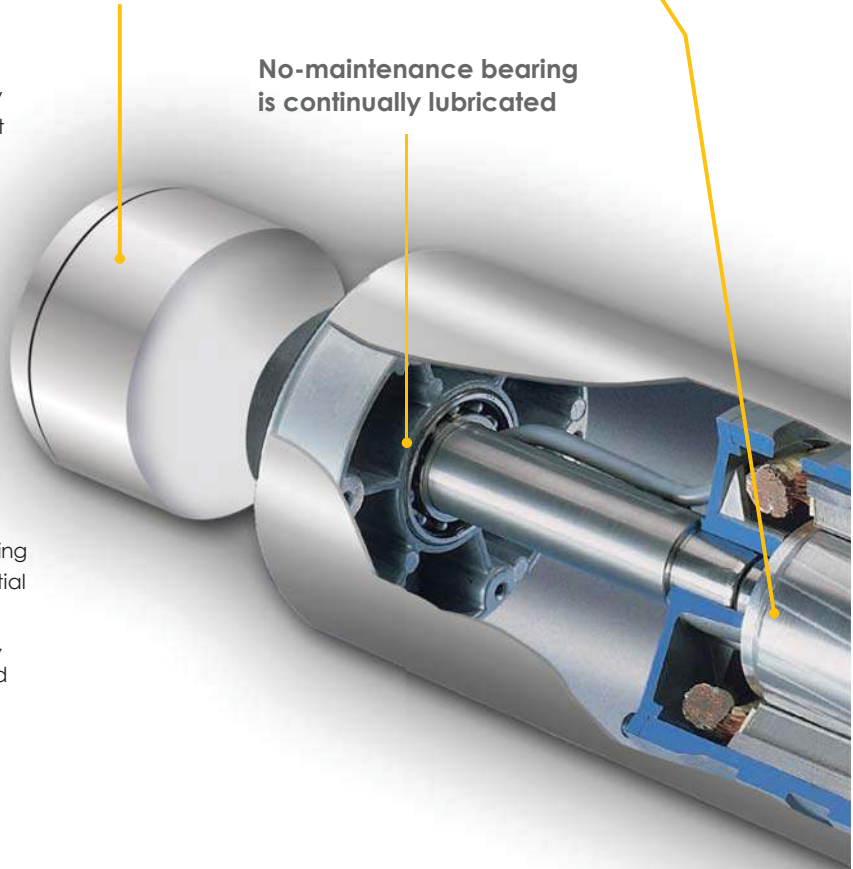

Conventional drive system

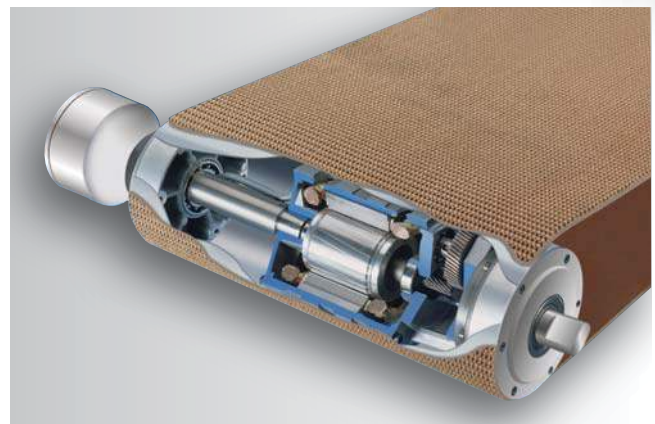

DURA-DRIVE PLUS motorized pulley

What is a motorized pulley?

A motorized pulley is a drum motor in which the body rotates around a stationary shaft. The rotating outer "drum" becomes the traction surface which powers the conveyor belt.

Electric power leads pass through the stationary shaft to motor terminals inside the pulley housing. Since the end shaft does not rotate, there is no need for slip rings to deliver electrical power to the motor windings.

The entire internal mechanism, including the motor, gears and bearings, are completely sealed and protected by the outer metal drum. Oil inside the drum continuously lubricates bearings and gears, and removes heat from motor windings.

Parallel gearing system for greater efficiency and quiet operation

Metallic labyrinth sealing to IP66 or IP67 keeps out dirt and water

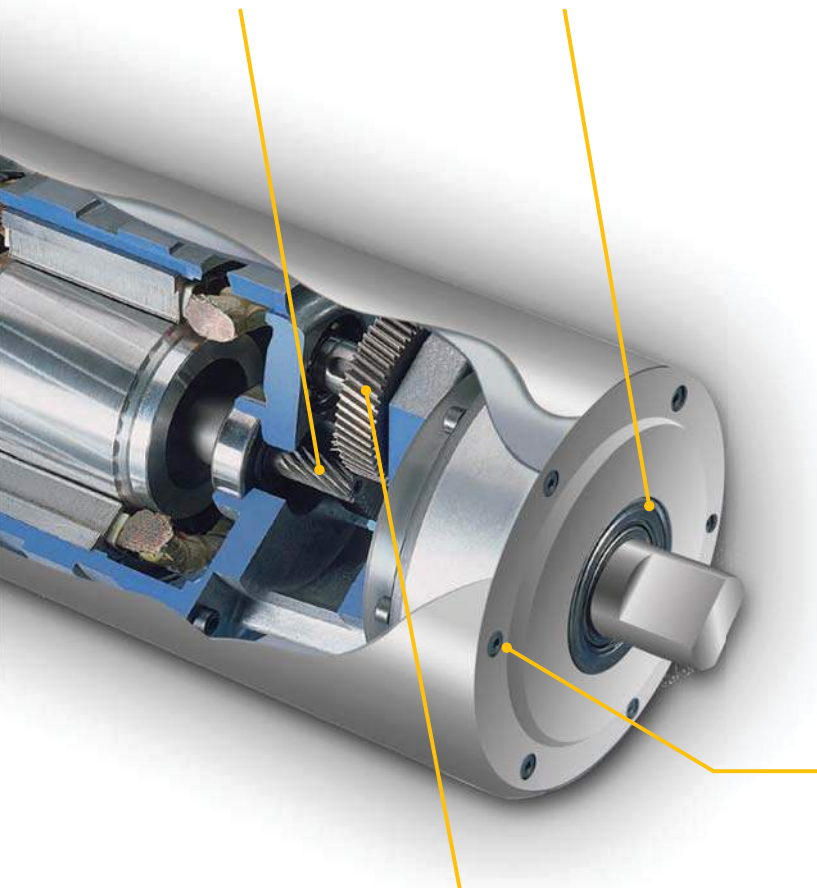

Quiet operation.

DURA-DRIVE PLUS operates at a very quiet 57-64 decibels, compared to 76-80 decibels for a typical conventional drive. Quieter operation can help you meet OSHA noise regulations, eliminate the need for costly ear protective devices for workers, and improve your overall work environment.

Simple design means easy specification for new systems, easy installation for existing ones.

Because **DURA-DRIVE PLUS** is a one-piece pulley and not 10 or more separate components like a conventional drive, it can be easily specified into new systems and dramatically reduce design time. For existing systems, the pulley comes with two mounting brackets and hardware. Changeover takes less than an hour per drive.

DURA-DRIVE PLUS...a cost-effective alternative to conventional drive systems.

DURA-DRIVE PLUS is priced competitively with conventional systems initially, and is more energy efficient. For example, a conventional system normally transfers only 60-75% of its mechanical efficiency (horsepower) to the belt. **DURA-DRIVE PLUS** transfers 95% of its capacity to the belt – a 20-35% increase.

This savings can translate into a reduction of hundreds of dollars in energy costs – *per drive, per year*. When you add in the reduced maintenance costs – *per drive, per year* – it's easy to see how **DURA-DRIVE PLUS** motorized pulleys can quickly pay for themselves, in a matter of months.

Other applications for motorized pulleys:

Motorized pulleys can be used for many applications. For example, by machining grooves in the shell or rubber lagging, the motor can be used to drive V-belt and round-belt driven conveyors.

Wheels and sprockets or special profiled lagging can be attached to the shell to drive plastic modular belts or chain conveyors.

Optional Bolt-on end cap for easy servicing

Gearing made of high-quality alloy steel with precision-cut helical and hardened polished teeth and gears, honed and ground for low noise.

3.19 Dura•Drive Plus

The **DURA-DRIVE PLUS** one piece motorized pulley is compact yet powerful. All gearing is made of high quality alloy steel ensuring years without breakdown. The **DURA-DRIVE PLUS** is also low maintenance with an in-place oil change after 40,000 hours. This ensures minimal downtime, which in turn ensures lower cost and higher productivity.



Shaft Seal

The end housings are fitted with custom designed one piece cartridge seals. This provides excellent protection against ingress of dust, grit, water and high-pressure cleanings. The cartridge seals are specially designed to prevent wear to the shafts.

Electric Motor

All Sparks Mol motorized pulleys contain motors tested to UL 1004 – 1:2012 standards with Class F insulation standard (Class H insulation available upon request). The motor is an asynchronous squirrel cage induction type. Class F motors are suitable for most applications with ambient temperatures of +100°F to -10°F. For temperatures above or below, contact Sparks Mol for a recommendation.

Electric motors with windings for special voltages and frequencies are available upon request.

Sparks Mol motorized pulleys are inverter duty motors and can, therefore, have a step-less speed control in combination with static frequency converters in the range from 30 to 70 HZ.

Electrical Connections

Pulleys in the 3.19" diameter line are not available in dual voltage or with a terminal box electrical connection.

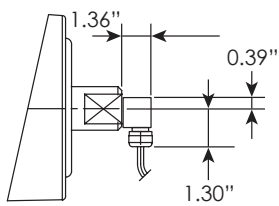

Thermo-plastic elbow connector with 5.5m cable

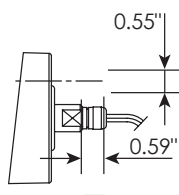

Straight connector and 5.5m cable

Constructions & Materials

Component	Standard	Options	Not available
Shaft	Mild Steel	Stainless Steel	
Shell	Mild Steel	Stainless Steel	
	Crowned	Hard Chrome	
		Rubber Lagged	
		Flat Face	
		V-Grooves	
End Caps	Aluminum	Stainless Steel	Mild Steel, Bolt on
		Pressed/glued	
Sealing Systems	Cartridge Seal		
Electrical Motor	3 Phase Asynchronous	Thermal Overload Protection	Single Phase
			Dual Voltage (face width restrictions)
			Wide Range Voltage
Electrical Connection	Straight Connector and 5.5m cable	Thermo-plastic Elbow Connector and 5.5m cable	Stainless Steel Terminal Box
			Steel Conduit Elbow Connector
Motor Insulation	Class F	Class H	



Motorized Pulley Dimensions

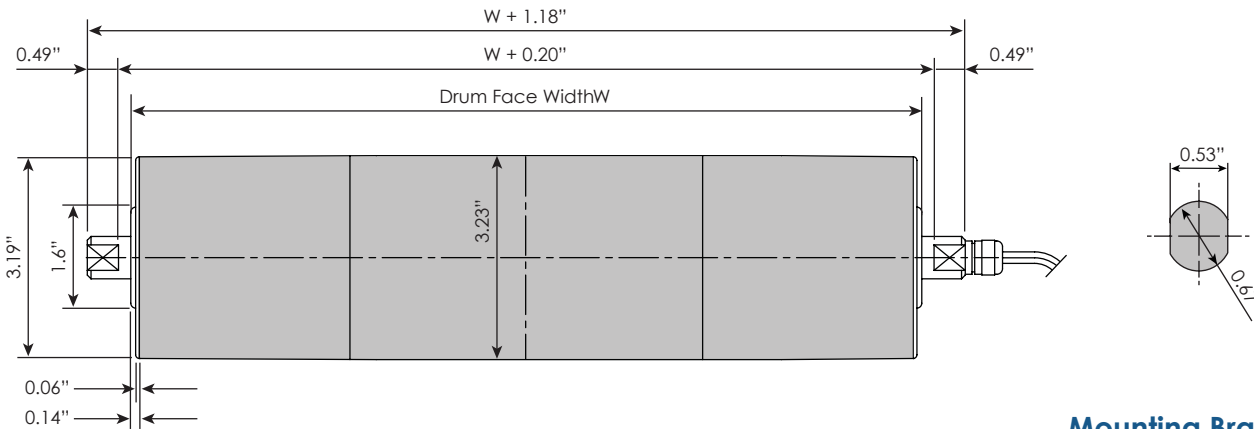

Idler Pulley Dimensions

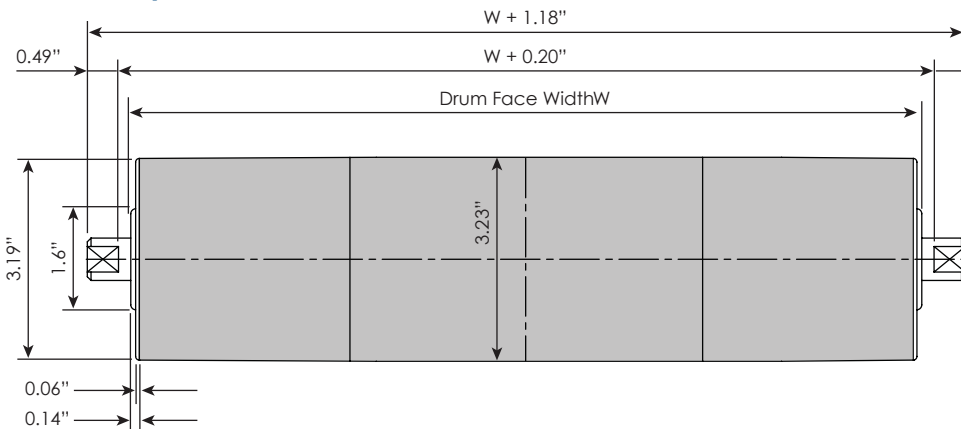

Mounting Bracket

Material: Cast iron or stainless steel bracket

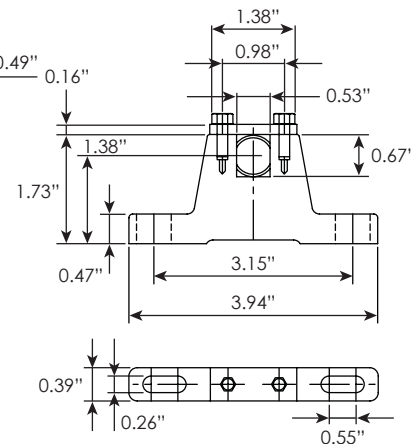

Performance Specifications

HP	Minimum Face Width	FPM (nominal)	Belt Pull (lbs)	Drum Torque (lbs ft)
0.16	9.84"	38	141	19
		54	89	12
		71	74	10
		94	56	7
		133	40	5
		189	28	4
		236	22	3

Standard Face Widths

11.81" (19 lbs)	13.78" (21 lbs)	15.75" (22 lbs)	17.72" (24 lbs)	19.69" (25 lbs)
21.65" (29 lbs)	23.62" (31 lbs)	25.59" (33 lbs)	27.56" (35 lbs)	29.53" (36 lbs)
31.50" (38 lbs)	33.46" (39 lbs)	35.43" (41 lbs)		

- Maximum face width is 59.50"
- Other face widths are available
- Maximum lagging thickness is 1/8" (8% increase in finished speed)
- V-groove option must be two times the min. face width and groove width
- Same diameter (3.23") grooved tube is only option
- All units are available in 3-phase single voltage, 230v or 460v
- No vertical mount
- Oversized Drum shell diameters larger than 3.23 are not available.

4.39 Dura•Drive Plus

The **DURA-DRIVE PLUS** one piece motorized pulley is compact yet powerful. All gearing is made of high quality alloy steel ensuring years without breakdown. The **DURA-DRIVE PLUS** is also low maintenance with an in-place oil change after 40,000 hours. This ensures minimal downtime, which in turn ensures lower cost and higher productivity.



Shaft Seal

The end housings are fitted with custom designed one piece cartridge seals. This provides excellent protection against ingress of dust, grit, water and high-pressure cleanings. The cartridge seals are specially designed to prevent wear to the shafts.

Electric Motor

All Sparks Mol motorized pulleys contain motors tested to UL 1004 – 1:2012 standards with Class F insulation standard (Class H insulation available upon request). The motor is an asynchronous squirrel cage induction type. Class F motors are suitable for most applications with ambient temperatures of +100°F to -10°F. For temperatures above or below, contact Sparks Mol for a recommendation.

Electric motors with windings for special voltages and frequencies are available upon request.

Sparks Mol motorized pulleys are inverter duty motors and can, therefore, have a step-less speed control in combination with static frequency converters in the range from 30 to 70 HZ.

Electrical Connections

Pulleys fitted with cables are normally supplied for one voltage only. Dual voltage cable is available upon request.

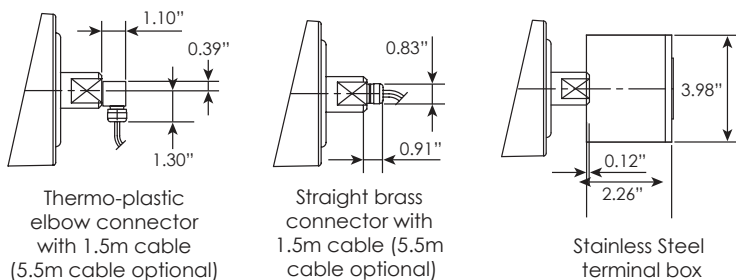

Constructions & Materials

Component	Standard	Options	Not available
Shaft	Mild Steel	Stainless Steel	
Shell	Mild Steel	Stainless Steel	
	Crowned	Rubber Lagged	
		Flat Face	
		V-Grooves	
		Sprockets	
		Hard Chrome	
End Caps	Aluminum	Stainless Steel	Mild Steel
	Pressed/glued	Bolt-on	
Sealing Systems	Cartridge Seal		
Electrical Motor	3 Phase Asynchronous	Dual Voltage	Single Phase
		Thermal Overload Protection	
Electrical Connection	Straight Brass Connector with 1.5m cable (5.5m cable optional)	Thermo-plastic Elbow Connector with 1.5m cable (5.5m cable optional)	
		Steel Conduit Elbow Connector with 1.5m cable (5.5m cable optional)	
		Stainless Steel Conduit Elbow Connector with 1.5m cable (5.5m cable optional)	
		Stainless Steel Terminal Box	
Motor Insulation	Class F	Class H	



Motorized Pulley Dimensions

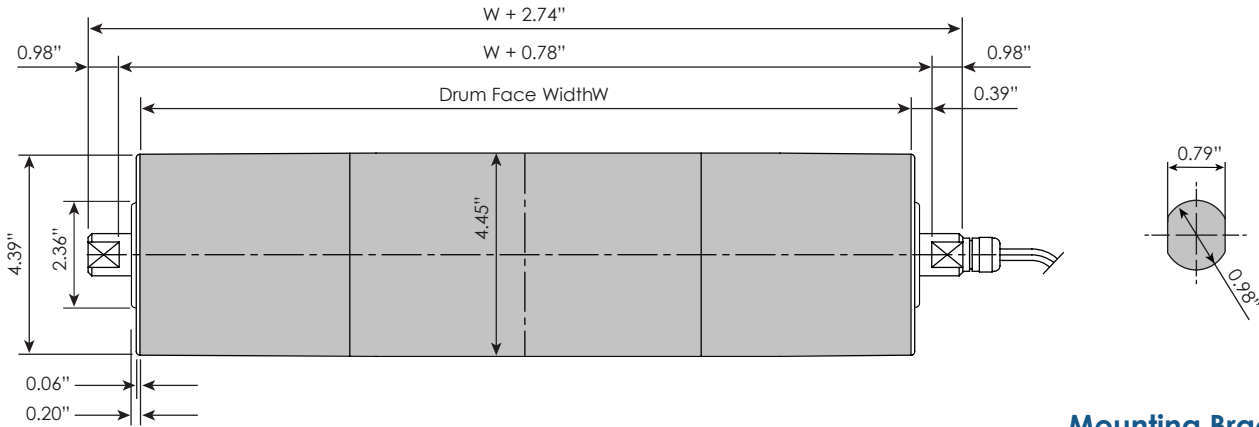

Mounting Bracket

Material: Cast iron or stainless steel bracket

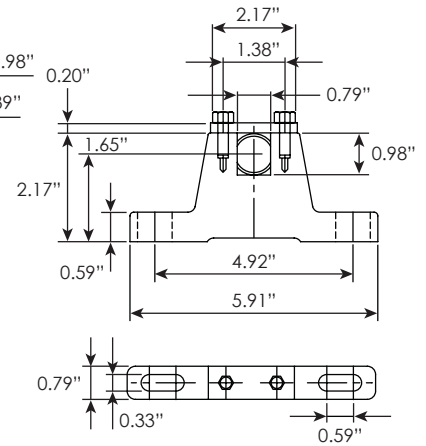

Idler Pulley Dimensions

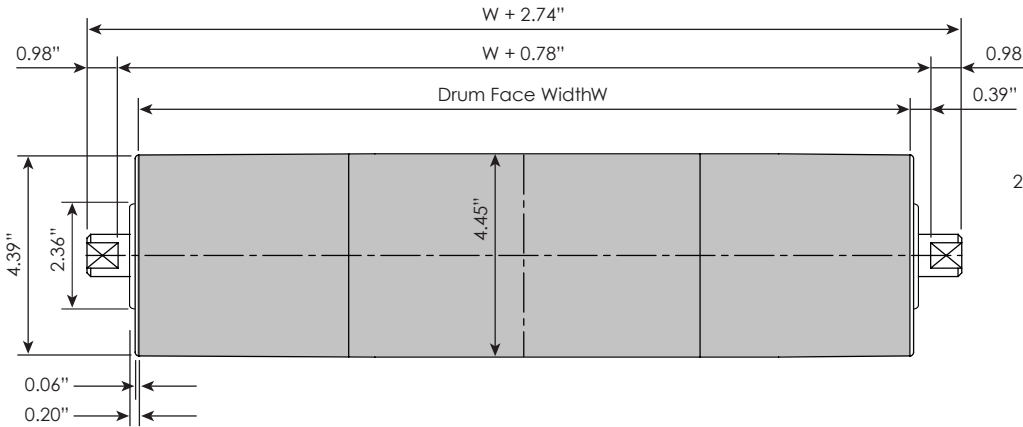

Performance Specifications

HP	Minimum Face Width	FPM (nominal)	Belt Pull (lbs)	Drum Torque (lbs ft)
0.2	9.84"	47	140	26
		65	97	18
		94	70	13
0.25	11.81"	29	289	53
		41	186	34
0.4	11.81"	47	280	57
		65	198	36
		71	186	34
		94	140	26
		104	124	23
0.5	11.81"	104	151	28
		118	140	26
		142	116	21
		189	87	16
		280	60	11
		325	49	9

Standard Face Widths

9.84" (30 lbs)	11.81" (31 lbs)	13.78" (33 lbs)	15.75" (36 lbs)	17.72" (37 lbs)
19.69" (39 lbs)	21.65" (41 lbs)	23.62" (43 lbs)	25.59" (46 lbs)	27.56" (49 lbs)
29.53" (51 lbs)	31.50" (53 lbs)	33.46" (56 lbs)	35.43" (58 lbs)	37.40" (60 lbs)

- Maximum face width is 59.50"
- Other face widths are available
- Add 1.97" to min. face width for bolt-on end caps
- Maximum lagging thickness is 1/8" (6% increase in finished speed)
- V-groove option must be two times the min. face width
- All motors can be single or dual voltage 230v or 460v 3 phase

5.38 Dura•Drive Plus

The **DURA-DRIVE PLUS** one piece motorized pulley is compact yet powerful. All gearing is made of high quality alloy steel ensuring years without breakdown. The **DURA-DRIVE PLUS** is also low maintenance with an in-place oil change after 40,000 hours. This ensures minimal downtime, which in turn ensures lower cost and higher productivity.



Shaft Seal

The end housings are fitted with custom designed one piece cartridge seals. This provides excellent protection against ingress of dust, grit, water and high-pressure cleanings. The cartridge seals are specially designed to prevent wear to the shafts.

Electric Motor

All Sparks Mol motorized pulleys contain motors tested to UL 1004 – 1:2012 standards with Class F insulation standard (Class H insulation available upon request). The motor is an asynchronous squirrel cage induction type. Class F motors are suitable for most applications with ambient temperatures of +100°F to -10°F. For temperatures above or below, contact Sparks Mol for a recommendation.

Electric motors with windings for special voltages and frequencies are available upon request.

Sparks Mol motorized pulleys are inverter duty motors and can, therefore, have a step-less speed control in combination with static frequency converters in the range from 30 to 70 HZ.

Electrical Connections

Pulleys fitted with cables are normally supplied for one voltage only. Dual voltage cable is available upon request.

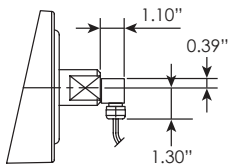

Thermo-plastic elbow connector with 1.5m cable (5.5m cable optional)

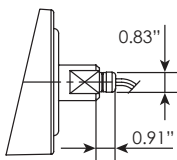

Straight brass connector with 1.5m cable (5.5m cable optional)

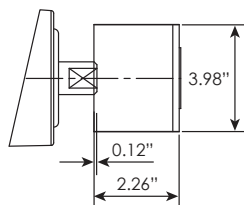

Stainless Steel terminal box

Constructions & Materials

Component	Standard	Options	Not available
Shaft	Mild Steel	Stainless Steel	
Shell	Mild Steel	Stainless Steel	
	Crowned	Rubber Lagged	
		Flat Face	
		V-Grooves	
End Caps	Mild Steel	Stainless Steel	Aluminum
	Pressed/glued	Bolt-on	
		Sprockets	
Sealing Systems	Cartridge Seal		
Electrical Motor	3 Phase Asynchronous	Dual Voltage	Single Phase
		Thermal Overload Protection	
Electrical Connection	Straight Brass Connector with 1.5m cable (5.5m cable optional)	Thermo-plastic Elbow Connector with 1.5m cable (5.5m cable optional)	
		Steel Conduit Elbow Connector with 1.5m cable (5.5m cable optional)	
		Stainless Steel Conduit Elbow Connector with 1.5m cable (5.5m cable optional)	
		Stainless Steel Terminal Box	
Motor Insulation	Class F	Class H	



Motorized Pulley Dimensions

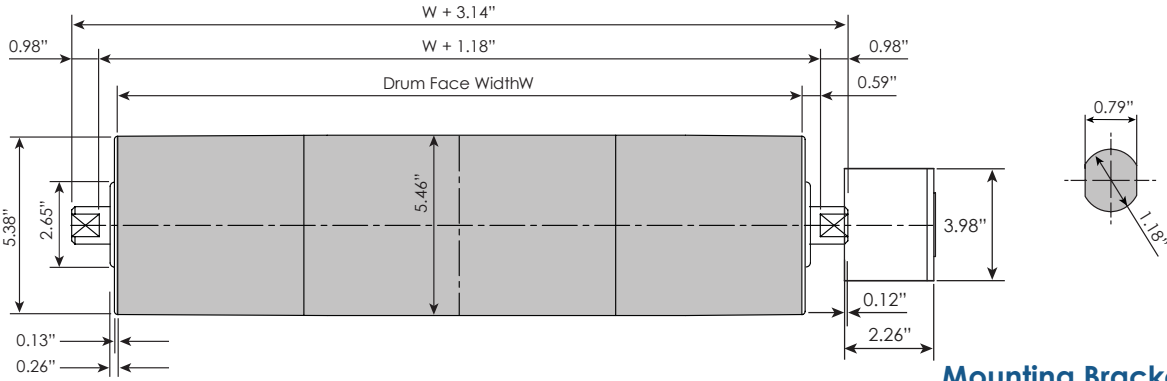

Mounting Bracket

Material: Cast iron or stainless steel bracket

Idler Pulley Dimensions

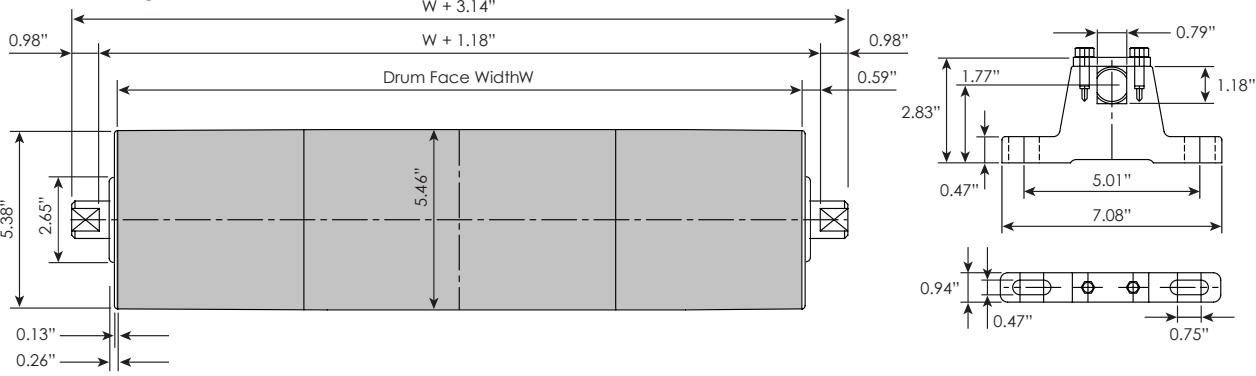

Performance Specifications

HP	Minimum Face Width	FPM (nominal)	Belt Pull (lbs)	Drum Torque (lbs ft)
0.25	13.78"	19	412	91
		26	422	93
		31	341	75
		54	196	43
0.5	11.81"	38	434	98
		47	351	78
		65	243	54
		85	185	41
		104	153	34
		133	117	26
0.75	11.81"	85	279	62
		104	225	50
		133	176	39
		175	135	30
		210	113	25
		280	86	19
		295	77	17
1	13.78"	430	54	12
		59	545	120
		85	381	84
		104	308	68
		133	240	53

Performance Specifications cont.

HP	Minimum Face Width	FPM (nominal)	Belt Pull (lbs)	Drum Torque (lbs ft)
1.5	13.78"	104	450	99
		133	354	78
		189	250	55
		260	182	40

Standard Face Widths

11.81" (53 lbs)	13.78" (55 lbs)	15.75" (57 lbs)	17.72" (59 lbs)	19.69" (62 lbs)
22.65" (65 lbs)	23.62" (68 lbs)	25.59" (71 lbs)	27.56" (73 lbs)	29.53" (76 lbs)
31.50" (51 lbs)	33.46" (83 lbs)	35.43" (85 lbs)	37.40" (87 lbs)	39.36" (89 lbs)

- Maximum face width is 81"
- Other face widths are available
- Add 1.97" to min. face width for bolt-on end caps
- Maximum lagging thickness is 3/8" (14% increase in finished speed)
- For V-groove tube diameter of 5.45", length must be 2 times the min. face width
- For V-groove tube diameter of 6.45", length can be same as min. face length (22% increase in finished speed)
- All motors can be single or dual voltage 230v or 460v 3 phase

6.46 Dura•Drive Plus

The **DURA-DRIVE PLUS** one piece motorized pulley is compact yet powerful. All gearing is made of high quality alloy steel ensuring years without breakdown. The **DURA-DRIVE PLUS** is also low maintenance with an in-place oil change after 40,000 hours. This ensures minimal downtime, which in turn ensures lower cost and higher productivity.



Shaft Seal

The end housings are fitted with custom designed one piece cartridge seals. This provides excellent protection against ingress of dust, grit, water and high-pressure cleanings. The cartridge seals are specially designed to prevent wear to the shafts.

Electric Motor

All Sparks Mol motorized pulleys contain motors tested to UL 1004 – 1:2012 standards with Class F insulation standard (Class H insulation available upon request). The motor is an asynchronous squirrel cage induction type. Class F motors are suitable for most applications with ambient temperatures of +100°F to -10°F. For temperatures above or below, contact Sparks Mol for a recommendation.

Electric motors with windings for special voltages and frequencies are available upon request.

Sparks Mol motorized pulleys are inverter duty motors and can, therefore, have a step-less speed control in combination with static frequency converters in the range from 30 to 70 HZ.

Electrical Connections

Pulleys fitted with cables are normally supplied for one voltage only. Dual voltage cable is available upon request.

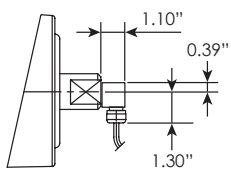

Thermo-plastic elbow connector with 1.5m cable (5.5m cable optional)

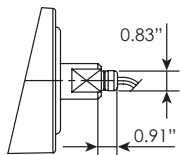

Straight brass connector with 1.5m cable (5.5m cable optional)

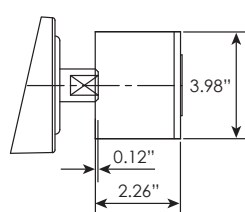

Stainless Steel terminal box

Constructions & Materials

Component	Standard	Options	Not available
Shaft	Mild Steel	Stainless Steel	
Shell	Mild Steel	Stainless Steel	
	Crowned	Rubber Lagged	
		Flat Face	
		V-Grooves	
End Caps	Mild Steel	Stainless Steel	Aluminum
	Pressed/glued	Bolt-on	
		Sprockets	
Sealing Systems	Cartridge Seal		
Electrical Motor	3 Phase Asynchronous	Dual Voltage	Single Phase
		Thermal Overload Protection	
Electrical Connection	Straight Brass Connector with 1.5m cable (5.5m cable optional)	Thermo-plastic Elbow Connector with 1.5m cable (5.5m cable optional)	
		Steel Conduit Elbow Connector with 1.5m cable (5.5m cable optional)	
		Stainless Steel Conduit Elbow Connector with 1.5m cable (5.5m cable optional)	
		Stainless Steel Terminal Box	
Motor Insulation	Class F	Class H	



Motorized Pulley Dimensions

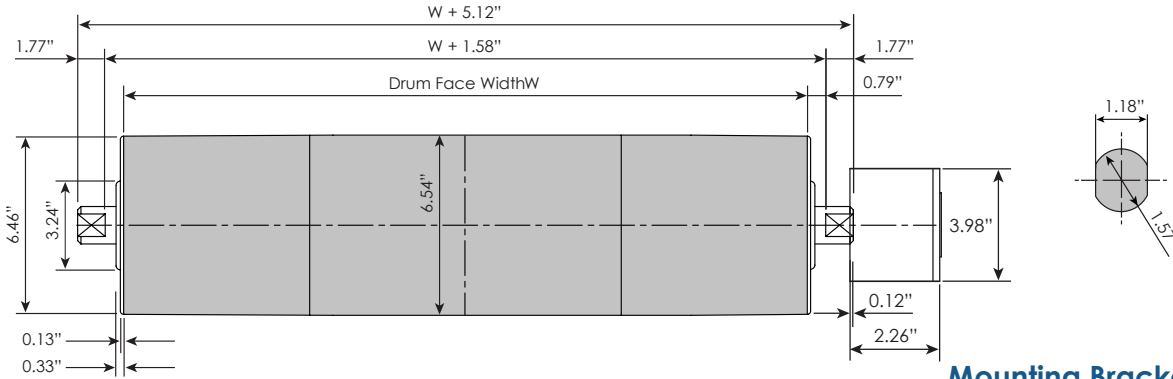

Mounting Bracket

Material: Cast iron or stainless steel bracket

Idler Pulley Dimensions

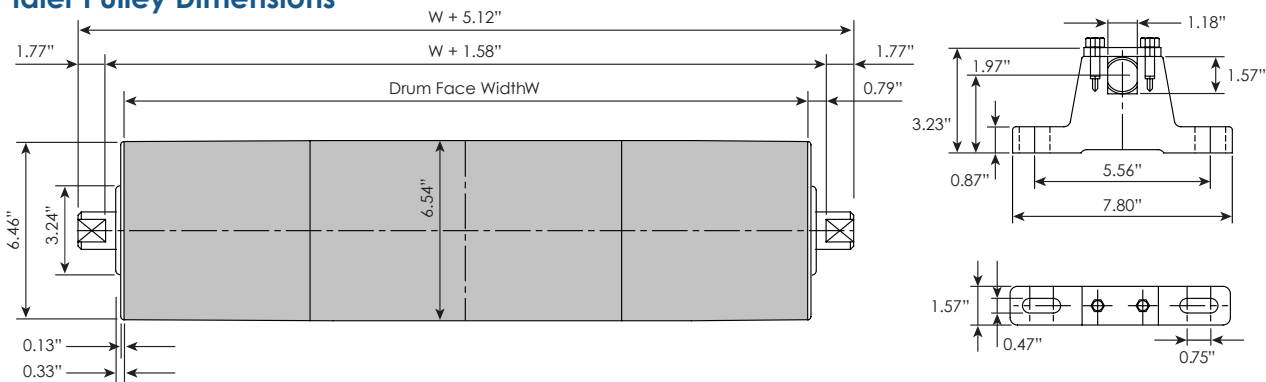

Performance Specifications

HP	Minimum Face Width	FPM (nominal)	Belt Pull (lbs)	Drum Torque (lbs ft)
0.5	17.72"	21	752	200
		31	797	212
		38	650	173
0.75	15.75"	47	526	140
		59	419	111
		104	227	60
		65	488	130
		74	439	117
1	15.75"	104	304	81
		118	266	71
		149	221	59
		189	175	47
		235	140	37
1	17.72"	38	867	231
		104	611	162
2	17.72"	118	539	143
		149	430	114
		189	351	93
		235	280	75

Performance Specifications cont.

HP	Minimum Face Width	FPM (nominal)	Belt Pull (lbs)	Drum Torque (lbs ft)
3	17.72"	118	838	223
		149	663	176
		205	468	124
		295	335	89
		374	253	67
		472	200	53

Standard Face Widths

15.75" (119 lbs)	17.72" (122 lbs)	19.69" (125 lbs)	21.65" (128 lbs)	23.62" (131 lbs)	23.62" (131 lbs)
27.56" (137 lbs)	29.53" (140 lbs)	31.50" (143 lbs)	33.46" (146 lbs)	35.43" (149 lbs)	37.40" (152 lbs)
39.36" (155 lbs)	41.33" (158 lbs)	43.30" (161 lbs)	45.27" (164 lbs)		

- Maximum face width is 96"
- Other face widths are available
- Add 1.97" to min. face width for bolt-on end caps
- Maximum lagging thickness is 3/8" (11% increase in finished speed)
- For V-groove tube diameter of 6.50", length must be 2 times the min. face width
- For V-groove tube diameter of 7.45", length can be same as min. face length (17% increase in finished speed)
- All motors can be single or dual voltage 230v or 460v 3 phase

8.48 Dura•Drive Plus

The **DURA-DRIVE PLUS** one piece motorized pulley is compact yet powerful. All gearing is made of high quality alloy steel ensuring years without breakdown. The **DURA-DRIVE PLUS** is also low maintenance with an in-place oil change after 40,000 hours. This ensures minimal downtime, which in turn ensures lower cost and higher productivity.



Shaft Seal

The end housings are fitted with custom designed one piece cartridge seals. This provides excellent protection against ingress of dust, grit, water and high-pressure cleanings. The cartridge seals are specially designed to prevent wear to the shafts.

Electric Motor

All Sparks Mol motorized pulleys contain motors tested to UL 1004 – 1:2012 standards with Class F insulation standard (Class H insulation available upon request). The motor is an asynchronous squirrel cage induction type. Class F motors are suitable for most applications with ambient temperatures of +100°F to -10°F. For temperatures above or below, contact Sparks Mol for a recommendation.

Electric motors with windings for special voltages and frequencies are available upon request.

Sparks Mol motorized pulleys are inverter duty motors and can, therefore, have a step-less speed control in combination with static frequency converters in the range from 30 to 70 HZ.

Electrical Connections

Pulleys fitted with cables are normally supplied for one voltage only. Dual voltage cable is available upon request.

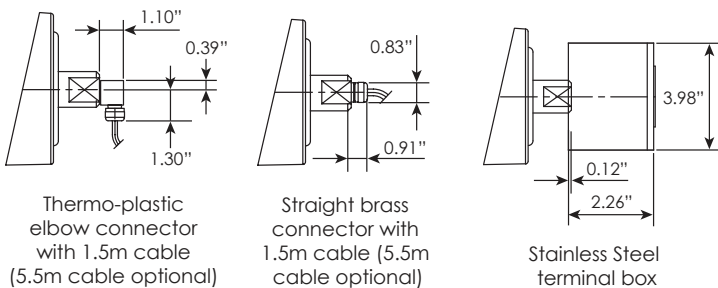

Constructions & Materials

Component	Standard	Options	Not available
Shaft	Mild Steel	Stainless Steel	
Shell	Mild Steel	Stainless Steel	
	Crowned	Rubber Lagged	
		Flat Face	
		V-Grooves	
End Caps	Mild Steel	Stainless Steel	Aluminum
	Pressed/glued	Bolt-on	
		Sprockets	
Sealing Systems	Cartridge Seal		
Electrical Motor	3 Phase Asynchronous	Dual Voltage	Single Phase
		Thermal Overload Protection	
Electrical Connection	Straight Brass Connector with 1.5m cable (5.5m cable optional)	Thermo-plastic Elbow Connector with 1.5m cable (5.5m cable optional)	
		Steel Conduit Elbow Connector with 1.5m cable (5.5m cable optional)	
		Stainless Steel Conduit Elbow Connector with 1.5m cable (5.5m cable optional)	
		Stainless Steel Terminal Box	
Motor Insulation	Class F	Class H	



Motorized Pulley Dimensions

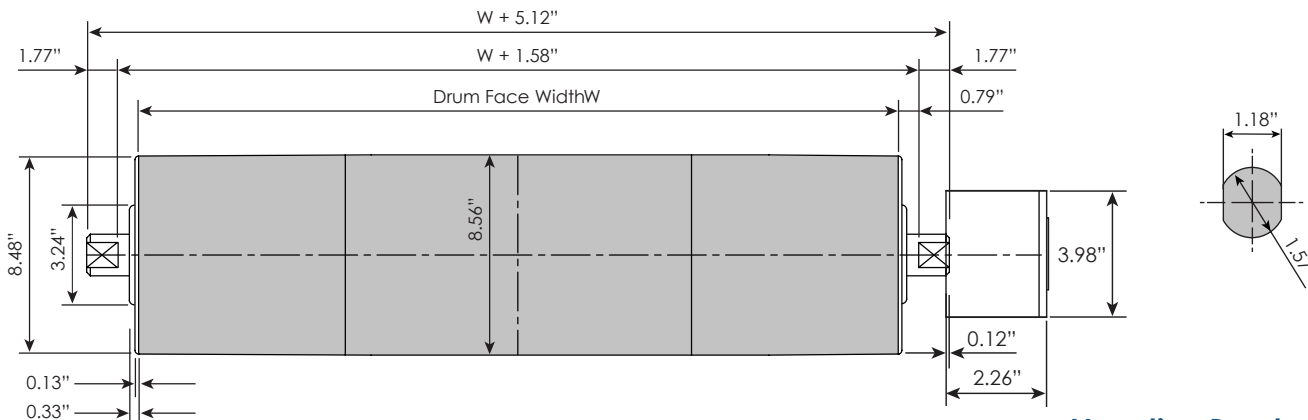

Mounting Bracket

Material: Cast iron or stainless steel bracket

Idler Pulley Dimensions

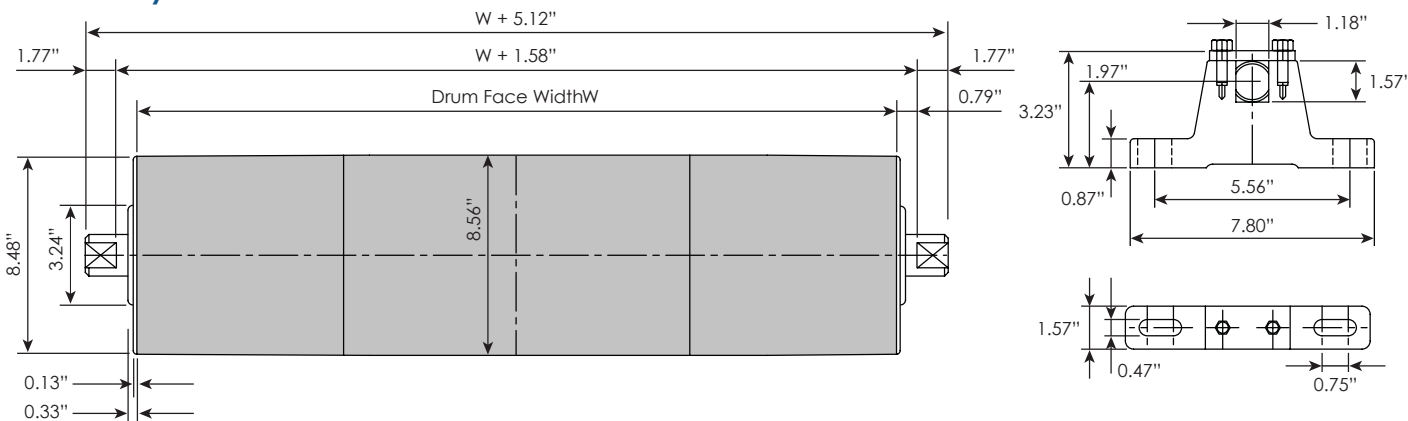

Performance Specifications

HP	Minimum Face Width	FPM (nominal)	Belt Pull (lbs)	Drum Torque (lbs ft)
1.5	19.69"	47	1052	372
		59	838	296
		76	650	230
2	19.69"	63	997	352
		80	824	291
3	19.69"	92	1075	380
		118	838	296
		149	663	234
4	19.69"	189	523	185
		149	840	296
		236	559	197
5.5	19.69"	295	447	158
		472	279	99
		295	614	217
		378	479	169
		472	384	136

Standard Face Widths

19.69" (129 lbs)	21.65" (134 lbs)	23.62" (138 lbs)	25.59" (142 lbs)	27.56" (146 lbs)
29.53" (150 lbs)	31.50" (154 lbs)	33.46" (160 lbs)	35.43" (170 lbs)	37.40" (180 lbs)
39.36" (189 lbs)	41.33" (198 lbs)	43.40" (208 lbs)	45.27" (217 lbs)	

- Maximum face width is 108"
- Other face widths are available
- Add 1.97" to min. face width for bolt-on end caps
- Maximum lagging thickness is 3/8" (9% increase in finished speed)
- For V-groove tube diameter of 8.56", length must be 2 times the min. face width
- For V-groove tube diameter of 9.45", length can be same as min. face length (12% increase in finished speed)
- All motors can be single or dual voltage 230v or 460v 3 phase



Sparks Mol
Innovative Conveyance Solutions